

90-Degree Elbow Cladding Machine

Hot Wire TIG Cladding for 90-Degree Pipe Elbow

90-Degree Elbow Cladding is a process of weld overlay of stainless steel inside 90-degree pipe elbow. KAIYUAN offers an unique system for 90-degree elbow cladding with Hot Wire TIG using a patented sector-wise cladding for consistent quality and high productivity.

Salient Features

- Patented technology – sector-wise cladding (two sectors) requires only one time fitment, saves time and man hour, improves productivity
- Cladding in 1G Position – cladding is done only in 1G position all throughout, which ensures best deposition rate.
- User friendly control and parameter setting – only 3 basic parameters, weld overlay, elbow ID and bending radius, all other parameters are set automatically by the system, which ensures high quality
- Automatic Voltage Control (AVC) – maintains constant stick-out, ensures proper penetration throughout and eliminates the issue of tungsten inclusion, consistent weld quality
- Torch Oscillation – weaving ensures better deposition.
- Non Volatile Memory – last weld overlay parameters are stored automatically and are retained in case of power failure, which can be easily recalled, saves time and improves quality.
- Available in two variants – SPM and Robotic to meet the desired user application.

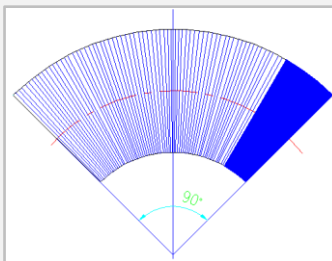
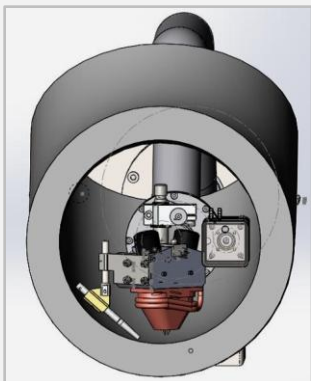

Sector-wise cladding (top right), positioning inside pipe (top left and below)

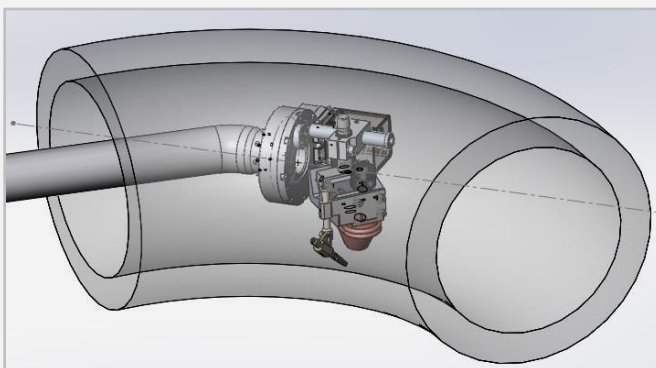

Technical Details	Value
Job Details	
Bend angle of the pipe	90 Deg
Inner diameter range	174 ~ 800 mm (160 mm after cladding)
Bending radius range	450 ~ 1000 mm
Maximum job weight	2500 Kgs
Working Environment	
Mains supply	415±10%V AC, 3Ph, 50Hz
Ambient temperature	-5 to +45 Deg C
Relative humidity	20 ~ 90% (non condensing)
Flammable Gas	No
Corrosive Gas	No
Shielding gas	Ar (purity ~ 99.99%)
Work site	Indoor

Special Features of KAIYUAN System

The KAIYUAN 90-Degree Elbow Cladding System with Hot Wire TIG comes with a patented technology and a wide range of features listed below.

S. No.	Parameter	KAIYUAN System Special Features
1	Wed segments	2
2	Torch adjustment (no. of times)	One Time
3	Clamping (no. of times)	One Time
4	Cladding position	Flat (1G)
5	Tracking	AVC
6	Cladding joints	One Joint (smooth)
7	Additional time during cladding	Zero
8	Manual interference	Nil (subject to proper mounting)
9	Cladding motion	Oscillation, automated for sector shape
10	Start / Stop points	4 nos.
11	Post weld treatment (grinding etc.)	Nil
12	Work time (e.g. elbow OD = 219 mm)	4 ~ 5 hours per layer

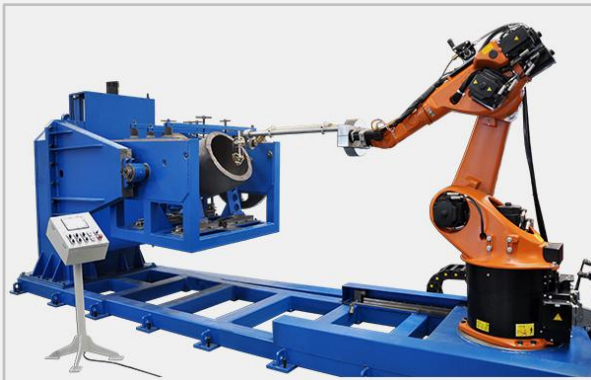

90-Degree Elbow Cladding System (Robotic Variant)



90-Degree Elbow Cladding System (SPM Variant)



Cut-sectional view of Elbow ID after Cladding

KAIYUAN WELDING & CUTTING AUTOMATION INDIA PVT. LTD.

Add: Plot No. 51, Gat No. 343, Chakan Talegaon Road, Pune - 410501, Maharashtra, India.

Contact No. +91 7755900873 +91-7755900921

Web: www.kaiyuan.in

E-mail: info@kaiyuan.in